

DH-HAC-T1A21P-U-A

2MP IR HDCVI Fixed-focal Eyeball Camera



- Max. 30 fps@1080p
- Smart IR Illumination
- 25 m illumination distance.
- Built-in Mic.
- Quick-to-install eyeball saves installation time.
- 3.6 mm fixed lens (2.8 mm optional).
- CVI/CVBS/AHD/TVI switchable.



Series Overview

The Cooper Series offers simple and highly cost-effective HDCVI solutions. It provides 24/7 reliable monitoring with high-quality image performance, saving cost on both material and labor force. It is also designed and built to the specific standards of Dahua.

Functions

Smart IR Illumination

With its IR illumination, the camera provides optimal performance in low light conditions, ensuring uniformity in the brightness of B/W images. Through its smart IR technology, the camera also compensates for the distance of targets by adjusting the intensity of its IR LEDs, preventing overexposure of images as targets move closer to the camera.

Easy Installation

HDCVI eyeball comes with a quick-to-install pedestal, which makes it easier to install than conventional eyeballs and reduces cost on time and labor.

4 Signals over 1 Coaxial Cable

HDCVI technology supports 4 signals (video, audio*, data and power) which are simultaneously transmitted over a coaxial cable. Dual-way data transmission allows the HDCVI camera to interact with the XVR to perform various actions such as sending control signals and triggering alarms. HDCVI technology also supports PoC, which makes the camera easy and quick to install.

* Audio input is available for select HDCVI camera models.

Long Distance Transmission

HDCVI technology provides long distance transmission in real time without transmission loss. It supports transmission distances up to 700 m for 2-MP/5-MP/8-MP HD videos through coaxial cables, and up to 300 m through UTP cables. The results were obtained and verified through rigorous testing in Dahua's test laboratory.

Simplicity

HDCVI technology inherits the simplicity of traditional analog surveillance systems, making it a great mechanism for protecting your valuables. HDCVI can be upgraded from the traditional analog system without replacing the existing coaxial cabling. Its plug and play design enables it to produce high-definition videos during surveillance without the hassle of configuring a network.

Technical Specification

Camera	
Image Sensor	2 MP CMOS
Max. Resolution	1920 (H) × 1080 (V)
Scanning System	Progressive
Electronic Shutter Speed	PAL: 1/25 s–1/100,000 s; NTSC: 1/30 s–1/100,000 s
Min. Illumination	0.02 lux@F2.0 (Color, 30 IRE) 0.002 lux@F2.0 (B/W, 30 IRE) 0 lux (Illuminator on)
S/N Ratio	>65 dB
Illumination Distance	25 m (82.02 ft)
Illuminator On/Off Control	Auto/Manual
Illuminator Number	1 (IR light)
Angle Adjustment	Pan: 0°–360° Tilt: 0°–78° Rotation: 0°–360°

Lens					
Lens Type	Fixed-focal				
Lens Mount	M12				
Focal Length	2.8 mm; 3.6 mm				
Max. Aperture	F2.0				
Field of View	2.8 mm: H: 100°; V: 54°; D: 117° 3.6 mm: H: 80°; V: 43°; D: 94°				
Iris Control	Fixed				
Close Focus Distance	2.8 mm: 0.5 m (1.64 ft) 3.6 mm: 0.8 m (2.62 ft)				
DORI Distance	Lens	Detect	Observe	Recognize	Identify
	2.8 mm	44.7 m (146.65 ft)	17.9 m (58.73 ft)	8.9 m (29.20 ft)	4.5 m (14.76 ft)
	3.6 mm	55.0 m (180.45 ft)	22.0 m (72.18 ft)	11.0 m (36.09 ft)	5.5 m (18.04 ft)
	*DORI (Detect, Observe, Recognize, Identify) is a standard system (EN-62676-4) for defining the ability of a person viewing the video to distinguish persons or objects within a covered area. The numbers in this table do not reflect intelligent function distances. For intelligent function distances, refer to installation and commissioning manual/project design tool.				

Video	
Video Frame Rate	CVI: PAL: 1080p@25 fps NTSC: 1080p@30 fps AHD: PAL: 1080p@25 fps NTSC: 1080p@30 fps TVI: PAL: 1080p@25 fps NTSC: 1080p@30 fps CVBS: PAL: 960H NTSC: 960H
Resolution	1080p (1920 × 1080); 960H (960 × 576/960 × 480)
Day/Night	Auto(ICR)/Color/B/W

BLC	BLC; DWDR
WDR	DWDR
White Balance	Auto
Gain Control	Auto
Noise Reduction	2D NR
Illumination Mode	Smart IR

Certification	
Certifications	CE-LVD: EN 62368-1; CE-EMC: EN 55032; EN 55035

Port	
Video Output	Video output choices of CVI/TVI/AHD/CVBS by one BNC port
Audio Input	One channel built-in Mic

Power	
Power Supply	12 VDC ± 30%
Power Consumption	Max 2.3 W (12 VDC, IR on)

Environment	
Operating Temperature	–40 °C to +60 °C (–40 °F to +140 °F)
Operating Humidity	<95% (RH), non-condensing
Storage Temperature	–40 °C to +60 °C (–40 °F to +140 °F)
Storage Humidity	<95% (RH), non-condensing
Anti-corrosion Level	Basic Protection

Structure	
Casing Material	Plastic
Product Dimensions	Φ85.0 mm × 77.1 mm (Φ3.35" × 3.04")
Net Weight	0.11 kg (0.24 lb)
Gross Weight	0.12 kg (0.26 lb)
Installation	Wall mount; ceiling mount

Ordering Information		
Type	Model	Description
2MP Camera	DH-HAC-T1A21P-U-A	2MP IR HDCVI Fixed-focal Eyeball Camera, PAL
	DH-HAC-T1A21N-U-A	2MP IR HDCVI Fixed-focal Eyeball Camera, NTSC
Accessories (Optional)	PFA12C	Plastic Junction Box
	PFM800-E	Passive HDCVI Balun
	PFM321D	12V 1A Power Adapter
	PFM904	Integrated Mount Tester

Dimensions (mm[inch])

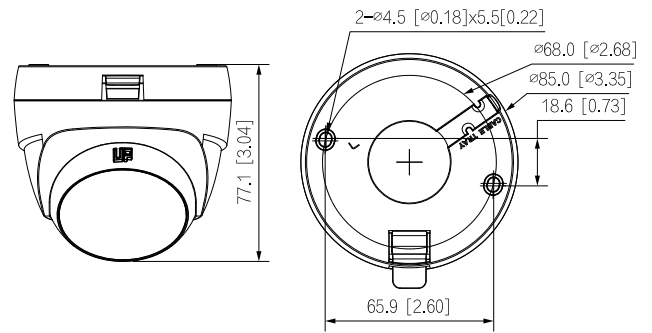

Accessories

Optional:



PFA12C
Plastic Junction Box



PFM800-E
Passive HDCVI Balun



PFM321D
12V 1A Power Adapter



PFM904
Integrated Mount Tester

